

# Adam

COMPACT ELECTRIC  
FIREPLACE SUITE

[www.adamfires.co.uk](http://www.adamfires.co.uk)

**These notes must be read before installation**

These instructions are for your safety. Please read through them thoroughly before use and retain for future reference. Failure to follow them could cause injury and/or property damage.

Note: This manual applies for a number of different products. Please make sure you follow the appropriate product guide lines.

**CONTENTS****SECTION 01**

Cautions	03-04
Introduction	05
Handling	05
Unpacking	05

**SECTION 02**

Tools required	06
Identification	06
Parts supplied	06
Fixings pack	06

**SECTION 03**

Installation	07
Assembly	08
Use	08
Care	08
Specification	09
Guarantee	12
Contacts	12

## CAUTIONS

### DO'S

---

- Always install the product in accordance with this guide. If in doubt obtain expert advice.

---

- Always make sure the electrical socket is accessible and located adjacent to, but not above the suite.

---

- Always disconnect the suite from the electrical supply before carrying out cleaning or maintenance.

---

- Always make sure the suite is firmly secured.

---

- Always ensure the product is assembled in an area that is free from dust, grease or liquids.

---

- Always ensure that the correct tools are used to mount this suite.

---

- Always make sure the suite is firmly secured to the wall when complete

---

### DON'TS

---

- Never leave children unsupervised in a room where the heater is ON and unguarded.

---

- Never obstruct or cover the fan outlet or force items into fire openings.

---

- Never install or use the suite anywhere where water is in use, i.e. Bathrooms, Kitchens, Shower Rooms, and Swimming Pool etc.

---

- Never use aerosols or steam cleaners on or around the heater.

---

- Never route the supply cord under carpet etc.

---

- Never install the suite close to curtains or combustible materials.

---

- Never use the suite to dry clothes etc.

---

- Never sit or stand on the suite.

---

- Never lean or put weight on the suite.

---

- Do not use outdoors.

---

## PLEASE DO NOT OBSTRUCT THE AIR VENTS OF THE SUITE'S HEATER UNIT

This appliance has a 'self resetting' safety cut out system. To prevent overheating, ensure the air inlets and outlets are not obstructed. If the safety cut-out operates, switch off the heater and allow to fully cool down. Remove any obstruction before re-use.

## IMPORTANT ELECTRICAL SAFETY

The socket must always be accessible in order to disconnect the suite from the electrical supply for maintenance and cleaning.

## IMPORTANT!

- Do not spray liquids directly onto any surface of the unit.
- This suite must be earthed. The supply cord must be safely routed from the suite to an electrical socket.
- If the supply cord is damaged, it must be replaced by the manufacturer or its service agent or a similarly qualified person in order to avoid a hazard.
- This appliance is not intended for use by persons (including children) with reduced physical, sensory or mental capabilities, or lack of experience and knowledge, unless they have had supervision or instruction concerning use of the appliance by a person responsible for their safety.
- Children should be supervised to ensure that they do not play with the appliance.
- The plug must be accessible after installation to allow for isolation in an emergency.
- This heater is not equipped with a device to control the room temperature. Do not use this heater in small rooms when they are occupied by persons not capable of leaving the room on their own unless constant supervision is provided.



Warning: In order to avoid overheating, **DO NOT COVER THE HEATER UNIT**

**Note:** Any new wiring required, must be in accordance with local and national codes and other applicable regulations in order to reduce the risk of fire, electric shock, or other injuries.

**Note:** When the suite is turned on for the first time or when it has not been used for some time, it may release a slight, harmless odour. This odour is a normal occurrence caused by the initial heating of the internal heating elements and will disappear with use.

## INTRODUCTION

Thank you for choosing this Electric Suite. The suite is designed to meet the most stringent quality, performance, and safety requirements. This guide aims to improve your understanding and appreciation of your new suite by providing simple and informative assembly instructions.

## HANDLING

Before continuing any further with the installation of this fire please read the following:

- When lifting always keep your back straight. Bend your legs and not your back.
- Avoid twisting at the waist. It is better to reposition your feet.
- Avoid upper body / top heavy bending. Always bend from the knees rather than the waist.
- Do not lean forward or sideways whilst handling the suite.
- Always grip with the palm of the hand. Do not use the tips of fingers for support.
- Always keep the product as close to the body as possible. This will prevent unnecessary and undue strain on the body.
- Use gloves to provide additional grip.
- Always use assistance if required.

## UNPACKING

The unit is supplied in a single package carton. Carefully unpack the product using the following procedure:

- Carefully lift the parts out of the box
- Carefully remove the protective wrapping from the parts
- Locate the fixing pack and put aside

## TOOLS REQUIRED

- Electric Drill (with 6mm masonry bit & 2mm wood bit).
- Crosshead screw driver (an electric screw driver is recommended).

## IDENTIFICATION

(Image for illustrative purposes only)

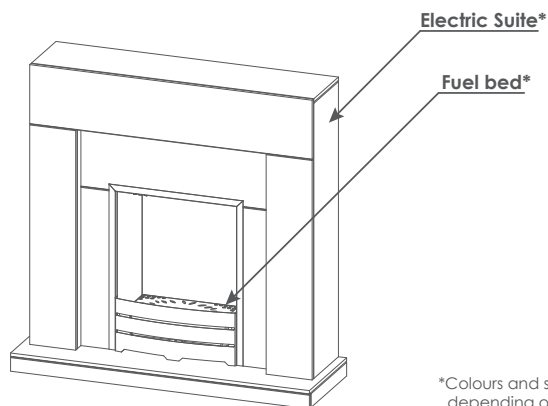

\*Colours and styles may vary depending on product

## PARTS SUPPLIED

- Electric Suite
- Loose coals/pebbles (Unless supplied with a fixed moulded fuel bed)

## FIXINGS PACK

<b>2x</b>	Mirror Clips
<b>4x</b>	1 6mm Screw
<b>2x</b>	32mm Screw
<b>2x</b>	Wall Plug

## INSTALLATION

Please ensure the floor and wall are flat before installation and that secure anchorage points can be made to the wall.

Before installing this product please take note that should removal or relocation of the product be necessary, any installation methods used may be left exposed.

NOTE: It is advised that an electric screwdriver is used throughout the installation of this product.

To secure the suite to the wall, follow the instructions below:

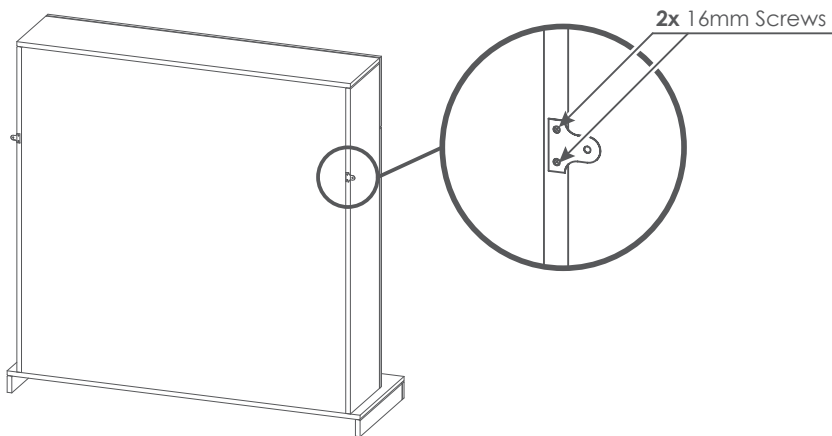

1. Attach a mirror clip to the back of each edge as shown using the 4 x 16mm screws. Pre-drill the holes (using a 2mm diameter drill bit) to prevent the MDF splitting.
2. Place the suite to the wall, and mark the positions of the remaining holes on both mirror clips. Check the wall does not have any wiring or pipe work behind where you intend to drill.
3. For solid walls: Using an electric drill (6mm bit), drill the two marked holes approximately 35mm deep into the wall.  
Note: If fitting the product to plaster board with a cavity behind then propriety wall fixings (not supplied) will be required. If in doubt, please seek advice from a suitably qualified tradesman.
4. Route the supply cord to exit the same side of the suite where the mains socket outlet is located. Check the supply cord is not trapped under the suite such that it may cause it to be damaged.
5. Insert the wall plugs, and then secure the suite with 2 x 32mm screws (supplied).

## ASSEMBLY

If your suite has a moulded fuel bed, no assembly is required.

If loose coals or pebbles were supplied with your suite, spread them out evenly on the bed of the fire.

## USE

The appliance is controlled using 3 switches, located **to the left of the heater unit**.

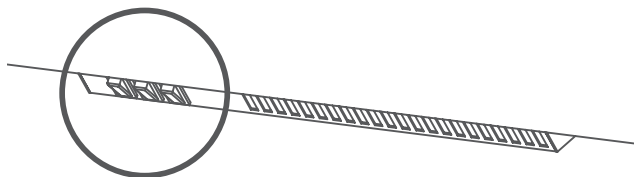

Use the following sequence to operate. The grey represents a 'pressed switch.' A switch is in the ON position when the side with the markings on (e.g. I or II) is 'pressed in'.

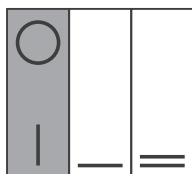

On/Off

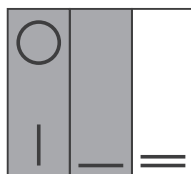

1kW Heat setting



2kW Heat setting

## CARE

- Brushed stainless steel fires can be cleaned using a cloth and propriety cleaner.
- Other features (non-silver) can be cleaned using a damp cloth.
- If the supply cord is damaged, it must be replaced by a suitably qualified person.
- The area around the suite should be kept free from animal hair, lint and other extraneous material that may be drawn into the workings of the appliance which could affect its performance.
- Due to the nature of the materials used in the construction of the fireplace surround, an amount of moisture may be absorbed should the surround remain in contact with liquids for prolonged periods.



## PLUG REPLACEMENT

(for product fitted with BS plug)

This appliance is supplied with a BS1363 3 pin plug fitted with a 13 Amp fuse. Should the fuse require replacement, it must be replaced with a fuse rated at **13 Amp** and approved to BS1362.

In the event the mains plug has to be removed/replaced for any reason, please note:

The wires in the mains lead on this appliance are coloured in accordance with the following code:

Green and Yellow - Earth  
 Blue - Neutral  
 Brown - Live

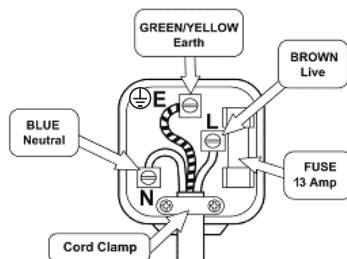

### THIS APPLIANCE MUST BE EARTHED

As the colours may not correspond with the markings identifying the terminals in your plug proceed as follows.

- The green and yellow earth wire must be connected to the terminal in the plug which is marked with the letter E or with the earth symbol (⊕)
- The blue wire must be connected to the terminal marked N
- The brown wire must be connected to the terminal marked L

Important - any cut off plug should be disposed of safely to prevent hazard. There is a danger of electric shock if a cut off plug is inserted into a socket outlet.

## SPECIFICATION

Supply Voltage	-	220-240V~50Hz
Rated Power	-	2000W
Fuse Rating (BS Plug)	-	13 Amp
Lighting		
Loose coals / Pebbles	-	3.4W LED Array (non serviceable)
Fixed moulded fuel bed	-	5W LED Array (non serviceable)
Class	-	1

**CONFORMITY WITH DIRECTIVES**

Conforms with relevant European Directives

**ENVIRONMENTAL PROTECTION**

- (WEEE) Waste Electrical and Electronic Equipment

Waste electrical products should not be disposed of with household waste. Please recycle where facilities exist. Check with your Local Authority or retailer for recycling advice.

- This appliance complies with the RoHS directive which restricts the use of certain hazardous substances in electrical and electronic equipment. This directive bans the placing on the EU market of new electrical and electronic equipment containing more than agreed levels of lead, cadmium, mercury, hexavalent chromium, polybrominated biphenyl (PBB) and polybrominated diphenyl ether (PBDE) flame retardants.





[ AFFIX RECEIPT OR PROOF  
OF PURCHASE HERE ]

## GUARANTEE

For your convenience, you are not required to complete a form and return it to us in order to validate your guarantee. However, please ensure that you retain your receipt which will act as both proof of purchase and a guarantee validation document. **We recommend that you attach your receipt to this documentation.**

Your product carries a 12 month guarantee from the date that the original purchaser receives it. If your product fails to operate to its specification, due to faulty workmanship or materials during the guarantee period, we will either repair or replace the product. We will use our discretion to determine whether to offer a repair or provide a replacement. The product will not be covered by the guarantee if it has been misused, transformed, modified or altered in any way.

If your product fails within the guarantee period please ensure that you have all necessary documentation available including proof of purchase (receipt or invoice with serial number, location and date of purchase) in addition to all original undamaged packaging and leaflets etc. It is strongly recommended that you inspect your product carefully before it is used or installed. For full details of your product you should refer to the instruction manual which accompanies the product. You are strongly advised to read this manual carefully in its entirety and to retain it for future reference.

This product guarantee does not affect your statutory rights.



[www.firedupgroup.co.uk](http://www.firedupgroup.co.uk)

Fired Up Corporation Ltd.  
Fired Up Buildings  
St Thomas Road  
Huddersfield  
HD1 3LF  
United Kingdom

---